

OS6-2

INTRODUCTION OF THE LATEST HYDRAULIC CONTROL SYSTEM FOR AUTOMATIC TRANSMISSION

Takashi SHIBAYAMA*, Hiroyuki YADA*, Yoshio MORITA* and Masumi FUJIKAWA*

*R&D Division , JATCO Ltd

BENEX S-3 , 3-20-8 Shin-Yokohama , Kohoku-ku , Yokohama City , Kanagawa 222-0033 Japan

ABSTRACT

From the social background of global warming issue, earth environment protection issue and the rise of oil price, the demand of the improvement of fuel economy and CO₂ reduction to a vehicle is very high nowadays. Continuously variable transmission (CVT) adoption has been recently increased to respond such social demand. JATCO is now also expanding the lineup of CVT as new solution for vehicle automatic transmission. In CVT, the shift control hydraulic pressure is a little bit higher than that of conventional stepwise shifting automatic transmission. So, unstable behavior of pressure is sometimes caused, for example, pressure oscillation. Such issue should be solved in early development stage. In this paper, we would like to introduce the feature and the techniques of oil pressure control system of CVT as an example of latest hydraulic control system for automatic transmission. And we would like to introduce our recent simulation for the optimal design of hydraulic control system.

KEYWORD

CVT , Fuel economy , Hydraulic simulation , Oil pressure stability

INTRODUCTION

The specific approach on the environmental problem is socially requested, for instance the Kyoto Protocol.

The technology for the improvement of fuel economy like the CO2 emission control etc. is assumed to be an important strategy of technology for an auto sector, and many companies are accelerating development to achieve the fuel economy improvement target. (Figure 1.)

Especially, the efficiency improvement of the power train composed by engine & transmission greatly contributes to the improving fuel economy. Regarding the transmission, the automatic transmission is a main current. And the share of it is 90 percent or more in Japan and the United States. Therefore, the further improvement as an environmental measure is expected to the automatic transmission. By such background, continuously variable transmission (CVT) adoption has been increased recently. Compared with stepwise shifting automatic transmission (STEP AT), CVT can make more flexible speed ratio, not stepwise, but continuously. By the flexibility of the CVT,

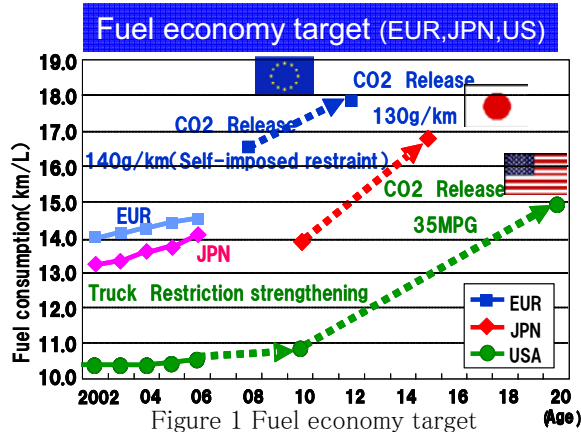

Figure 1 Fuel economy target

the engine operation condition can be maintained at optimal point for fuel economy. Moreover, CVT is very simple and that is good to adopt vehicle without greatly changing the system of the vehicle. It is simpler than the fuel cell vehicle system or the hybrid vehicle system. Therefore, recently, CVT adoption is expanding as a general technology for contribution to environment protection.

The torque capacity of CVT used to be small. It had started for the small, compact vehicle. But currently, CVT exists from the light vehicle to large vehicle with displacement volume 3.5L engine.

It shows that CVT has become very common, available technique for almost all vehicles which are general front wheel drive vehicle. By such background, as the one of main movement of transmission, automobile manufacturer has expanded the model equipped with CVT. (Figure 2)

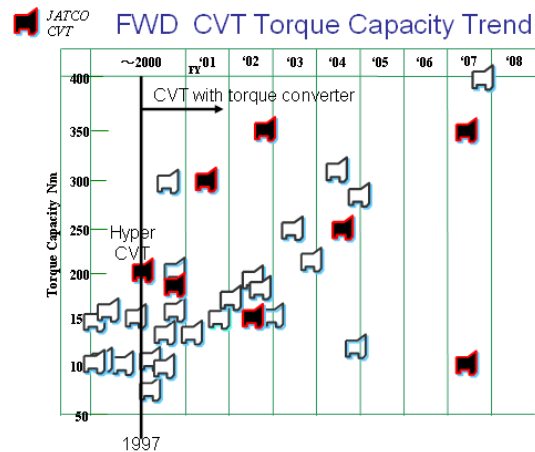

Figure 2 FWD CVT Torque Capacity Trend

CVT Unit structure

This chapter describes the belt CVT that is the main current in the CVT.

Regarding the structure of the CVT, several improvement has been developed. The big topic was adopting torque converter. Since "Hyper-CVT" that was released in 1997 by Nissan, torque converter starting system has become very common for CVT.

Figure.3 shows the torque flow of the CVT. Figure.4 shows the current typical CVT internal structure.

The torque input from the engine is input to the planet gear through the torque converter.

D range, R range, and the neutral are switched by a planet gear and multiple plate clutch combination.

The output torque from the planet gear is input to input pulley of the variator. And output from the output side pulley is transmitted to reduction

gears. And, the torque is distributed by differential gear to right and left driveshaft and it is output to the tires finally.

The shift control is operated by pulley actuator.

Beside the input pulley, a hydraulic control piston is equipped and also beside the output pulley another hydraulic control piston is equipped. In shifting, these two piston are actuated by hydraulic pressure, and the two pulleys are moved to adequate position to get targeted speed ratio. The multiple plate clutch for obtaining forward and reverse is also controlled by hydraulic pressure. Torque converter inner pressure is also controlled by same hydraulic control device. In such way, hydraulic control system has many roles for CVT.

CVT Hydraulic Control System

Figure 5 shows the outline of the CVT hydraulic control system.

Figure 6 shows the CVT hydraulic control unit.

The oil pump is driven by the drive chain (Refer to Figure 4) that is set on the engine input shaft and the oil pressure is generated.

The oil pressure from the oil pump is regulated by Pressure Regulator Valve (P.Reg), and this regulated oil pressure becomes supply pressure to the pulley.

The oil that remains by P.Reg flows to Clutch Regulator Valve (CL.Reg.) that is in the downstream.

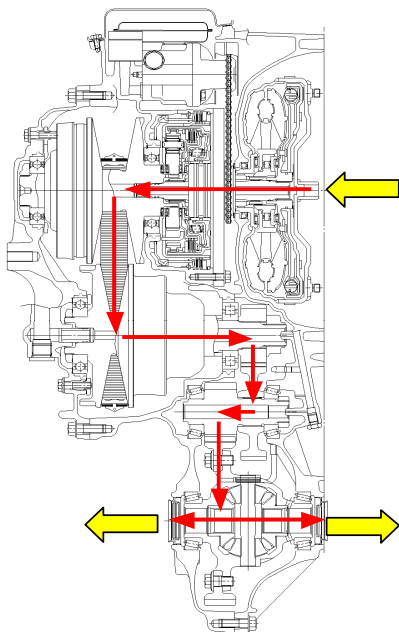

Figure 3 The torque flow of the CVT

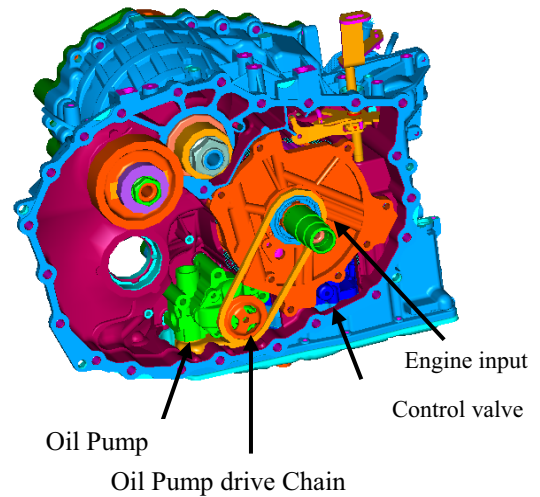

Figure 4 the current typical CVT internal structure

The oil pressure from P.Reg is regulated by CL.Reg proportionately to the P.Reg pressure, and this oil pressure becomes supply pressure of the clutch.

In addition, the oil that remains by CL.Reg flows to Torque Converter Regulator Valve (T/C.Reg) that is in the downstream. It is regulated to constant pressure in T/C.Reg, and this oil pressure becomes supply pressure to Torque Converter.

At each driving condition, an optimal oil pressure is calculated by the CVT control unit(C/U). And, it is input from C/U to each actuator (solenoid valve and Stepping Motor (S/M)) as a output signal. Therefore, oil pressure can be optimized proportionately to the torque. As a result, the friction loss by an excessive oil pressure can be reduced.

When changing the speed ratio, S/M is operated.

The speed ratio is changed by operating Shift Control Valve (SC/V) connected with S/M. Primary pulley is set on extension line of SC/V and S/M. The oil pressure is adjusted physically detecting the pulley position by this structure.

The pulley oil pressure is automatically adjusted by physically controlling the position. An optimal changing speed is achieved by this technology not being influenced to differences of parts. In addition, it contributes to the reduction of the friction loss by the oil pressure accuracy.

This mechanism is a typical technology for CVT ratio

control. There is another technology, that has not have such mechanical link, with directly pulley pressure control system. Input pulley and output pulley actuator pressures are directly controlled by solenoid valves.

The merit and the demerit of the two systems are exist. We cannot say which is better or not. Today, we would like to mention about the former system.

Recent trend for CVT oil pump is vane pump driven by chain. This system can reduce oil pump drive torque and is contributing to improve CVT efficiency.(Figure.7) And further development is proceeding around pump technology. Variable displacement pump or part time operating pump, for example electric driven pump, will be the technique for near future. Because CVT control system needs a little bit higher pressure than that of STEP AT(CVT:5.7MPa MAX , STEP AT:1.8MPa MAX), the reduction of oil pump loss is very important for fuel economy. So that such new pump improvement technology is now eagerly waited.

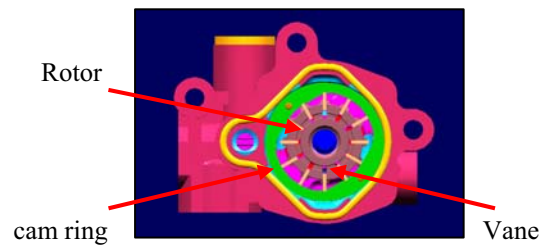

Figure 7 O/P ASSY(vane pump)

And another issue caused by the little bit higher pressure utilization compared with STEP AT is system stability. If the pressure becomes higher, it is sometimes caused unstable issue, for example pressure oscillation. Such issue require long time for solve. For the smooth development of new control system, a system stability analysis is very important. It is necessary to predict such stability issue and to facilitate adequate countermeasure in early development stage.

With such back ground, JATCO has recently developed simulation system for predict hydraulic pressure behavior for CVT control hydraulic system. In the next paragraph, we would like to mention about our hydraulic simulation system.

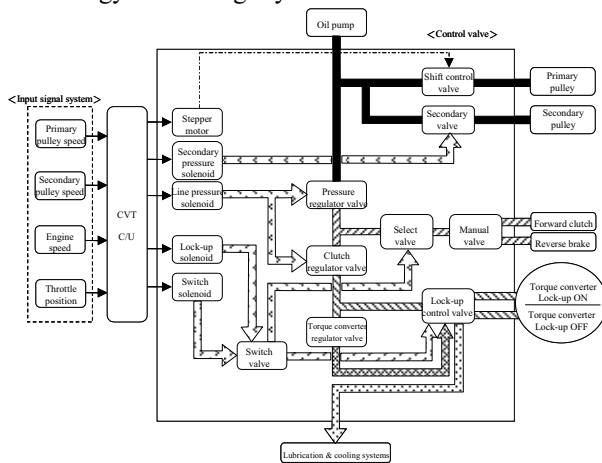

Figure 5 Outline of the CVT hydraulic control system.

CVT HYDRAULIC SIMULATION

Figure 8 shows the control model of the CVT hydraulic control system.

Oil pressure stability

The simulation technique and the result concerning the stability of the valve are described.

For example, the simulation model of Torque Converter Pressure is assumed to be a model like Figure 9.

When oil flows from the upstream (solid line) and it reaches the given pressure, the port of spool valve is opened and the remaining oil is exhausted (short dashes line).

We confirmed the oil pressure stability at the moment of opening the port when SPOOL is operated. (Figure 10)

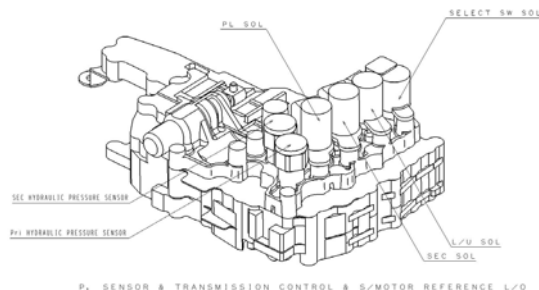

Figure 6 Hydraulic Control unit

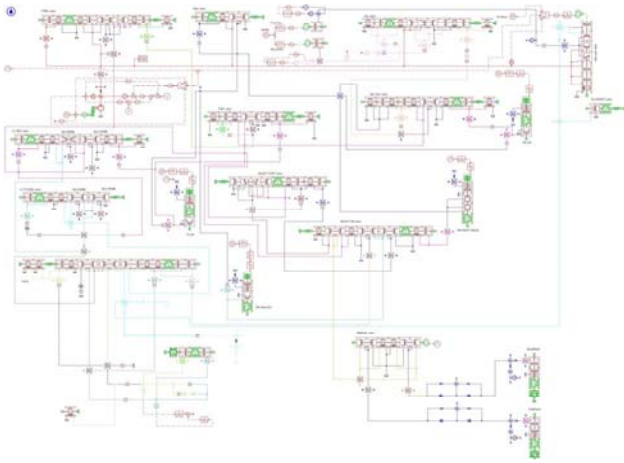

Figure 8 AME-Sim Full model

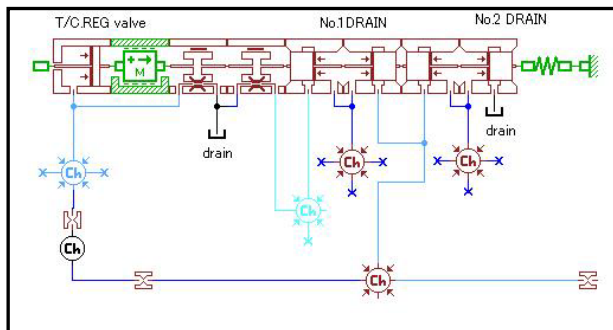

Figure 9 Simulation model (T/C Reg.)

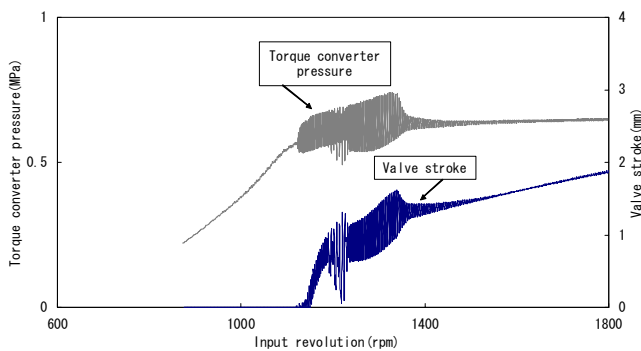

Figure 10 The behavior of T/C Reg pressure and T/C Reg stroke

In an initial setting, the problem about oil pressure stability turned out in the calculation.

Then, by confirmation of the sensitivity and the correlation between the feedback orifice area and Torque Converter Pressure, optimal orifice diameter was set. In addition, by experimenting, the validity of the simulation was confirmed. (Figure 12)

It shows that the experiment results correspond to the simulation results.

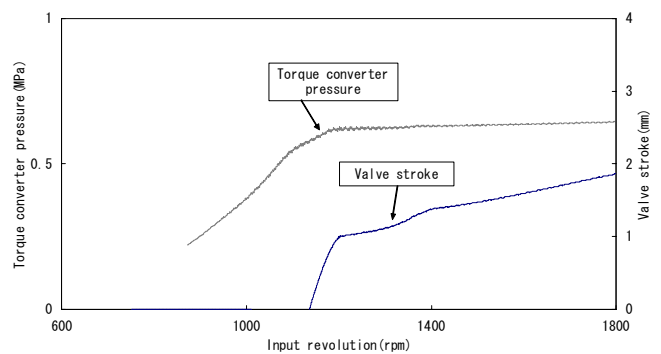

Figure 11 The behavior of the Torque Converter Pressure (The most suitable orifice diameter)

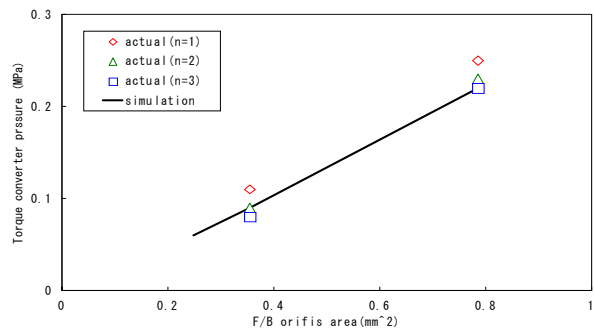

Figure 12 The correlation of the orifice diameter and the Torque Converter Pressure

SUMMARY

In this paper, the outline of latest hydraulic system of transmission, future direction of the technology, the typical concerning, and the solution technology with an example of CVT hydraulic system are described..

JATCO would like to continue to contribute to the social demand, progress of transmission technology and the progress of fluid power technology.

REFERENCES

1. Tatsuo Wakahara et al: "Hydraulic System, Shift and Lockup Clutch Controls Developed for the Large torque Capacity CVT3", Jatco Technical Review No.5 ,2004.
2. K.Abo, "Development of New-Generation Belt CVTs with High Torque Capacity for Front-Drove Cars", SAE 2003-01-0593,2003
3. S.Segawa and K.Adachi , "Design method for the slip speed control system of a lockup clutch(II)", JSAE Lecture Series,20025528
4. K.Adachi ,T.Wakahara et al : "Robust control system for continuously variable belt transmission", JSAE Review, 9930036,1999
5. Tatsuo Wakahara and Hirohisa Tanaka: "Research of Hydro-Mechanical Shift system of Belt-CVT to improve both efficiency and performance", JFPS Review 2005.11
6. Oshita et al., "Hydraulic System, Shift and Lockup Clutch Controls Developed for a Large Torque Capacity CVT", 04CVT-7, Intl. CVT & Hybrid Congress 2004
7. Yamamoto, et al., "DEVELOPMENT OF A NEW-GENERATION STEEL-BELT CVT FOR USE WITH 3.5L ENGINES", F2004F446, FISITA World Congress 2004