

P1-21

DIRECT DRIVE ELECTRO-HYDRAULIC SERVO ROTARY VANE STEERING GEAR

Jihai JIANG*, Wenhai SU* and Qinghe LIU*

* Institute of Fluid Power Transmission and Control, School of Mechatronics Engineering
Harbin Institute of Technology
Harbin 150001, Republic of China
(E-mail:jjhlxw@hit.edu.cn hitswh@163.com)

ABSTRACT

This paper describes the design and prototype of a new highly reliable rotary vane steering gear of ships which combines the benefits of conventional hydraulic systems and direct drive electrical actuators, namely high torque ratio and modularity. It is referred to as the Direct Drive Electro-Hydraulic (DDEH) servo rotary vane steering gear which results from the fusion of the above mentioned technologies. The DDEH rotary vane steering Gear, including its configuration, controlling principle and specialty, is theoretically analyzed. The mathematical models are built and the simulations of the system are made. The analysis of DDEH rotary vane steering gear is supported by simulation data which explains the extremely high level of performance attained by a prototype of DDEH rotary vane steering gear. Simulation results and its unique advantages show that DDEH rotary vane steering Gear is a prospective equipment for shipping steering which can meet performance requirements.

KEY WORDS

DDEH, Rotary Vane Steering Gear, Economizing, Simulation

INTRODUCTION

A rotary vane steering gear consists of a vane actuator connected directly to the rudder stock. It can control simply the direction of the ship through changing the angle of the moving vane. Rotary vane steering gear operates at lower pressures and has fewer moving parts than a ram steering gear. The rotary vane steering gear has many benefits, such as compact structure, space saving units, easy installation, and low life cycle costs. Furthermore, rotary vane steering gear does make safer navigation through narrow straits, because the vessels increased maneuverability and improved control when docking. Now, the rotary vane steering gear has a proven service record on all types of vessels, especially suit for medium-sized to large ships, including large container vessels and VLCCs [1-3]. The traditional controlling way of steering gear includes

using proportional valve or using variable displacement pump. Both kinds of methods require very higher cleanliness of hydraulic system because of adopting precise hydraulic parts. Furthermore, traditional steering gear has complex control system and lots of control components, acting as hidden troubles for failure free operation of steering gear [4-5]. To solve these problems, the direct drive electro-hydraulic(DDEH) servo rotary steering gear is designed and constructed by HIT. In this new prototype of steering gear, variable displacement pump and proportional valve are replaced by converter motor and fixed pump, so system needs lower cleanliness. The DDEH servo steering gear is discarded pumping station and pipelines. It has fewer control components and higher reliability and controllability than traditional rotary vane steering gear. Moreover, this steering gear can economize energy efficiently.

CONFIGURATION AND PRINCIPLE OF THE DDEH SERVO ROTARY VANE STEERING GEAR

Figure 1 shows Principle sketch of DDEH servo rotary steering gear. There are four main parts in this DDEH servo system: computer control system, variable frequency speed regulation system, hydraulic power actuator and displacement feedback union. Computer control system incepts input signal and signal by displacement feedback union. The main controller compares two signals and operates, and then translates

result to D/A converter. Finally, inverter incepts DC volts and drives asynchronous motor thus control hydraulic power actuator. Motor drives the bidirectional fixed displacement pump and then the pump drives the rotary vane motor directly. Changing the rotating direction, rotating speed and runtime of the motor can control the moving direction, velocity and position of the rudderpost which is fixed with rotary vane motor's stator.

Figure 2 presents the structure of hydraulic power actuator.

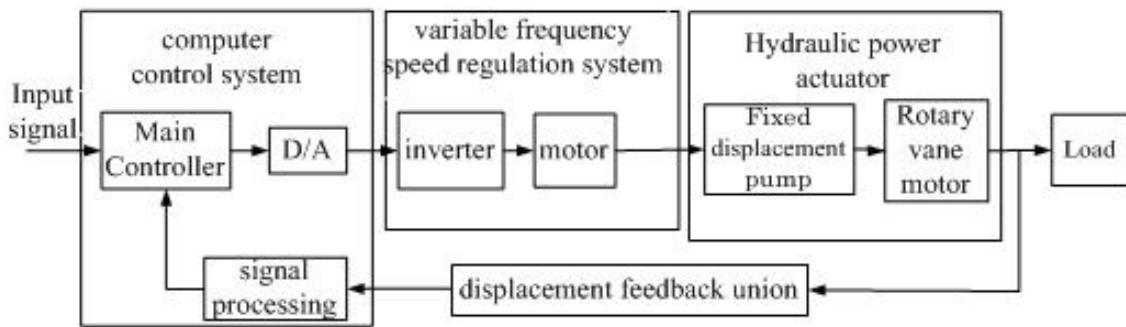
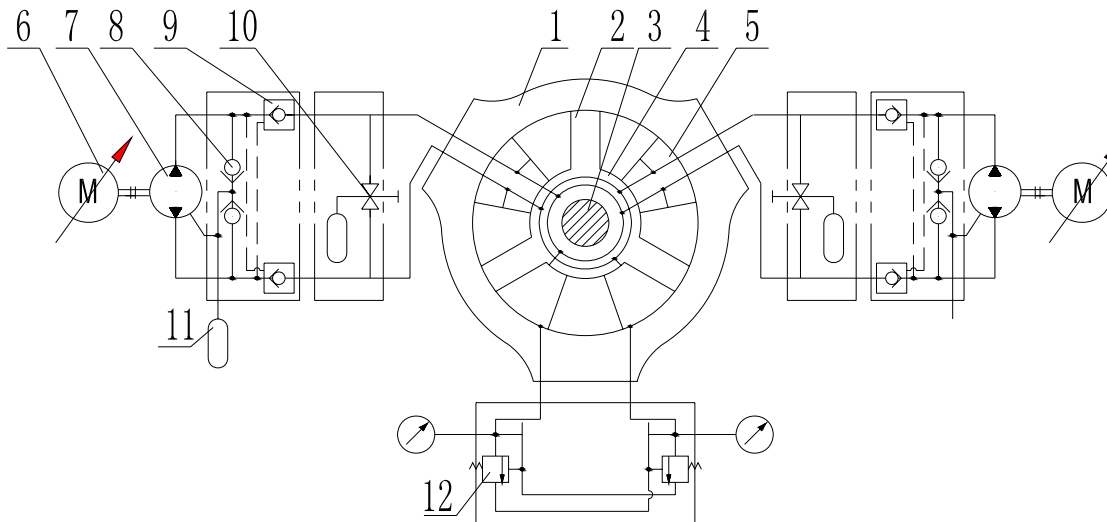

Figure 1 Principle sketch of DDEH servo rotary steering gear



1. housing 2. rotor 3. rudder stock 4. moving vane 5. stator 6. AC motor 7. bidirectional fixed pump
8. filling valve 9. hydraulic operated check valve(hydraulic lock) 10. stop valve 11. oil tank 12. safety valve

Figure 2 Construction drawing of DDEH servo rotary steering gear

In Figure 2, the closed circuit is composed of a fixed displacement pump 7 and rotary vane motor. AC motor 6 drives the bidirectional fixed displacement pump to provide hydraulic power (pressure and flow) to the rotary vane motor. Then through rudderpost, the hydraulic power is transformed into mechanical power (torque and rotating speed). The moving of the

rudderpost is carried out through controlling the AC motor according to the input signal. The filling valve 8 composed of two check valves is connected in parallel with the closed circuit to compensate the leak oil. The lock valve 9 is composed of two pilot operated check valves installed in series in the closed circuit. When the ship rudder reaches the right position and the pump

stops working, the lock valve functions as a lock to prevent the oil in the cylinders from moving back because of the action of wave on the ship rudders. Two relief valves are installed in the closed circuit to relieve overload when the ship rudder stops working and the overload is produced by wave acting on the ship rudder. The two relief valves can also be used to relieve overload in the main circuit. If the overloading occurs in the whole system, then the overload relieving is mainly achieved through the inverter's self-restricting torque.

MATHEMATICAL MODEL OF THE DDEH ROTARY VANE STEERING GEAR

The overall mathematical model of the DDEH rotary vane steering gear consists of several subsystems including the inverter-motor system, pump control motor system and actuator load system, et al.

INVERTER AND ASYNCHRONOUS MOTOR

INVERTER

Input of inverter is control voltage while output of inverter are frequency of output and phase voltage of electric machine stator [6]. We have

$$f_1 = K_v \cdot u_c \quad (1)$$

where K_v = conversion coefficient for translate voltage to frequency

u_c = control voltage, V.

f_1 = frequency of inverter output, Hz.

$$U_1 = \frac{(380-b)}{100} \cdot f_1 + b \quad (2)$$

where U_1 = phase voltage of electric machine stator, V.

b = low frequency torque upgrade coefficient,

When b is settled as zero, we obtain

$$U_1 = K_f \cdot f_1 \quad (3)$$

where K_f = conversion coefficient for translate voltage to frequency, $K_f = 3.8$.

ASYNCHRONOUS MOTOR

Asynchronous motor's equilibrium of moments equations is given by

$$\frac{2\pi}{60} \cdot J_T \frac{dn_p}{dt} = T_n - T_{LT} - T_{df} - \frac{2\pi}{60} B_T n_p \quad (4)$$

where T_n = electromagnetic torque of asynchronous motor, Nm.

T_{LT} = load torque of asynchronous motor, Nm.

T_{df} = nonlinear friction torque of asynchronous motor, Nm.

J_T = moment of inertia referred to motor shaft, kgm^2 .

B_T = damping factor of asynchronous motor shaft, Nms/rad.

Electromagnetic torque equilibrium of asynchronous motor

$$T_n = K_{T1} U_1 - K_{T2} n_p \quad (5)$$

where n_p = real rotary speed of asynchronous motor, rpm.

Load torque of asynchronous motor is input torque of fixed pump. when take loss of mechanical drive, T_{LT} can be given by

$$T_{LT} = \frac{D_p p_p}{\eta} \quad (6)$$

where D_p = volumetric displacement of pump, m^3/rad

p_p = output pressure, Pa

η = efficiency of mechanical drive, this

$$\eta = 0.95$$

PUMP CONTROLLED MOTOR

The continuity equation and torque balance equation can be written as

$$\frac{2\pi}{60} n_p D_p = D_m \frac{d\theta_m}{dt} + C_l P_1 + \frac{V_0}{\beta_e} \frac{dP_1}{dt} \quad (7)$$

$$P_1 D_m = J_s \frac{d^2 \theta_m}{dt^2} + B_m \frac{d\theta_m}{dt} + G \theta_m + T_L(\theta) \quad (8)$$

where D_m = volumetric displacement of motor, m^3/rad .

V_0 = Average volume of forward chamber, m^3 .

θ_m = angular position of motor shaft, rad.

$C_l = C_{il} + C_{el} =$ total leakage coefficient, $\text{m}^3/\text{sec}/\text{pa}$.

$C_{il} = C_{ip} + C_{im} =$ total internal leakage coefficient, $\text{m}^3/\text{sec}/\text{pa}$.

$C_{el} = C_{ep} + C_{em} =$ total leakage coefficient, $\text{m}^3/\text{sec}/\text{pa}$

$C_{ip}, C_{ep} =$ internal and external leakage coefficient of pump, $\text{m}^3/\text{sec}/\text{pa}$.

$C_{im}, C_{em} =$ internal and external leakage coefficient of motor, $\text{m}^3/\text{sec}/\text{pa}$

$p_1 =$ forward chamber pressure, pa

$\beta_e =$ effective bulk modulus of system, pa

$J =$ total inertia of motor and load, $\text{kg}\cdot\text{m}^2$

$B_m =$ total viscous damping coefficient, $\text{N}\cdot\text{m}/(\text{rad}/\text{s})$

$G =$ spring stiffness of load, $\text{N}\cdot\text{m}/\text{rad}$

$T_L(\theta) =$ hydrodynamic moment on rudder blade,

$$= 1/2(C_L \cos \theta_m + C_D \sin \theta_m) \rho A v^2 X_\varepsilon, \text{N}\cdot\text{m}$$

where C_L, C_D is lift coefficient and resistance

coefficient, v is water velocity and $v = 1.15-1.2$ ship speed, A is unilateral area of wetted surface, ρ is seawater density and X_ϵ is distance between center of rudder pressure and tiller axes.

MATHEMATICAL MODEL IN TIME DOMAIN

Combines equations being given at last section, mathematical model of DDEH rotary vane steering gear in time domain are described by

$$f_1 = K_v \cdot u_c \quad (9-1)$$

$$U_1 = K_f \cdot f_1 \quad (9-2)$$

$$\frac{2\pi}{60} \cdot J_T \frac{dn_p}{dt} = T_n - T_{LT} - T_{df} - \frac{2\pi}{60} B_T n_p \quad (9-3)$$

$$T_n = K_{T1} U_1 - K_{T2} n_p \quad (9-4)$$

$$T_{LT} = \frac{D_p P_p}{\eta} \quad (9-5)$$

$$\frac{2\pi}{60} n_p D_p = D_m \frac{d\theta_m}{dt} + C_i P_1 + \frac{V_0}{\beta_e} \frac{dP_1}{dt} \quad (9-6)$$

$$P_1 D_m = J_s \frac{d^2 \theta_m}{dt^2} + B_m \frac{d\theta_m}{dt} + G \theta_m + T_L \quad (9-7)$$

$$T_L(\theta) = 1/2(C_T \cos \theta_m + C_D \sin \theta_m) \rho A v^2 X_\epsilon \quad (9-8)$$

SIMULATION OF THE DDEH ROTARY VANE STEERING GEAR

SIMULATION MODEL AND PARAMETERS

System of equations 3.9 can be Laplace transforming and be combined to form the block diagram in Figure 3. θ_0 is steering orders and θ is rudder angle. Based on figure 3, DDEH rotary steering gear simulation model, is implemented in SIMULINK. Bump union is a main subsystem of this model, which is composed of AC converter motor, fixed pump, hydraulic lock and filling valve.

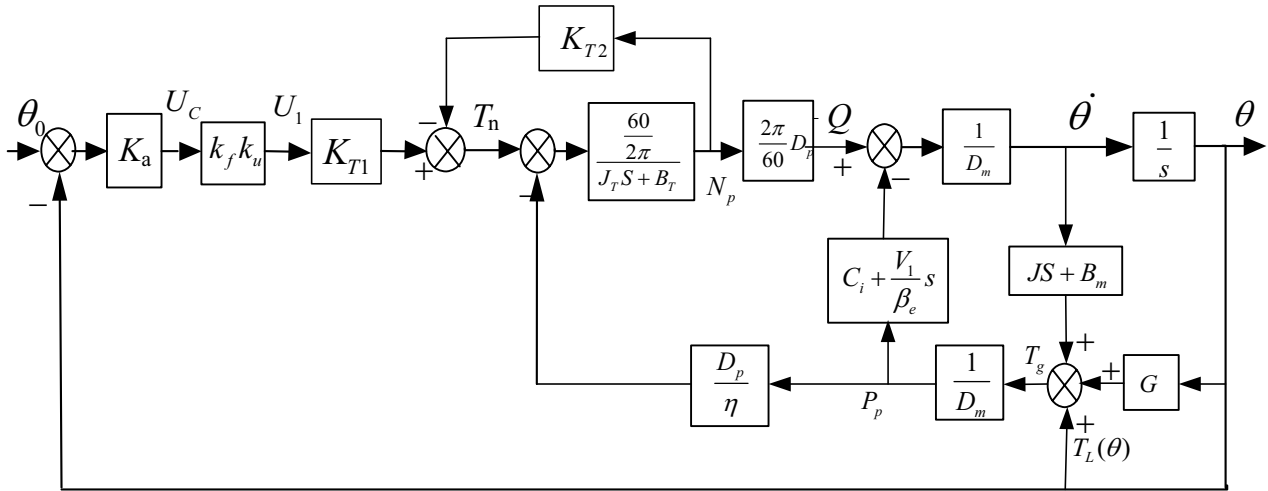

Figure 3 Block diagram of DDEH servo rotary steering gear

Part parameters of the DDEH rotary steering gear selected in this paper are shown in Table 1.

Table 1 parameters for simulation

parameters	value	parameters	value
K_v	10 Hz/V	D_m	0.04 m ³ /rad
K_f	3.8 V/Hz	J_m	3 kgm ²
K_{T1}	26.27	B_m	0.01 Nms/rad
K_{T2}	1.927	C_i	10 ⁻¹² m ⁵ /Ns
J_T	0.1 kgm ²	β_e	9×10 ⁸ N/m ²
B_T	0.01 Nms/rad	V_0	0.03 m ³
D_p	3.98×10 ⁻⁶ m ³ /rad		

SIMULATION RESULTS

Steering gear should meet the requirements for enough torque moment and intensity. SOLAS Regulation I/29.3.2 requires that the main steering gear and rudder stock of vessels shall be capable of putting the rudder over from 35° on one side to 35° on the other side when the ship is at its deepest seagoing draught and running ahead at maximum ahead service speed and, under the same conditions, from 35° on either side to 30° on the other side in no more than 28s[7].

In this paper, a 12,000 DWT crude oil tanker which is running ahead at 13 knot is selected as simulation background. Simulation time is selected as 50 second and original steering angle of vessel is -35° . The steering order changes to 30° since 20 second later. Simulation results are shown in Figure 4 and figure 5. It can be seen in figure 4 that the time of rudder movement is less than 28s. Figure 5 shows that steering gear can output 120KNm torque moment when it turns to 35 degree. Simulation results indicate that DDEH servo rotary vane steering gear meets the requirements of SOLAS.

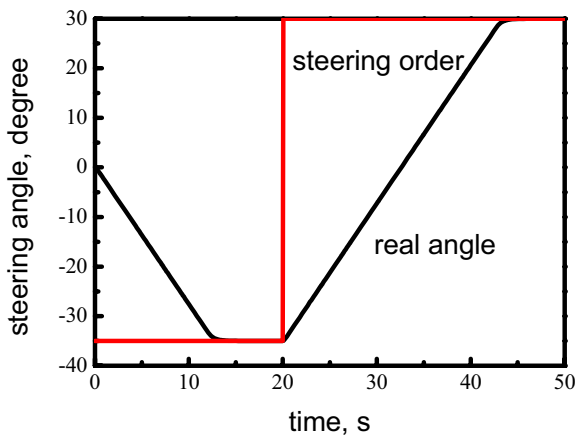

Figure 4 simulation result of steering angle

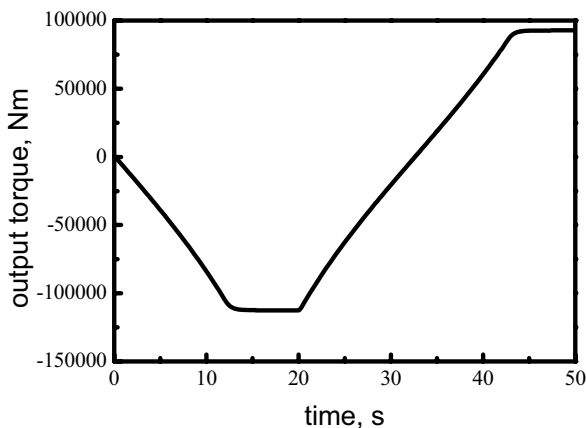

Figure 5 simulation result of torque moment

CONCLUSIONS

A new type steering gear - DDEH servo rotary vane steering gear is designed which is capable both advantages of AC servo system's flexibility and of hydraulic great force. Research results show that DDEH servo rotary vane steering gear measures up SOLAS. Because it has higher efficiency and more compact structure, DDEH servo rotary vane steering gear will have a great prospect in this field.

REFERENCES

1. Wagner Paul, Vail Jeannine A. EVOLUTION OF A MODERN NAVAL STEERING SYSTEM. Naval Engineers Journal, v 99, n 3, May, 1987, p 55-64
2. Anon. Frequency-controlled pumps enhance rotary-vane steering gear. Naval Architect, n, July/August, 2001, p 39
3. Ruosong Cui. Analysis of Some Key Techniques of Rotary Vane Steering Gear, shanghai shipbuilding, February, 2007, p 27-28
4. Changing Chen. Several rivers servo breakdown reason brief analysis. China Water Transport (Academic Version), 2006, vol.6 No.7, 19-20
5. Lianzhong Qi. Analysis and control the hydraulic oil contamination of actuator. Journal of Naval Aeronautical Engineering Institute, 2006, vol.21 No.6 618-622.
6. Achim Helbig, Injection moulding machine with electric-hydrostatic drives, 3rd international fluid power conference, Aachen, Germany, 2002
7. Protocol of 1978 relating to the international convention for the safety of life at sea, 1974

