

AN ENERGETIC COMPARISON BETWEEN VALVELESS AND VALVE CONTROLLED ACTIVE VIBRATION DAMPING FOR OFF-ROAD VEHICLES

Bastian EGGERS, Dr. Robert RAHMFELD, Prof. Monika IVANTYSYNOVA

Purdue University, Agricultural and Biological Engineering,
MAHA Fluid Power Lab
3601 Sagamore Pkwy North, Lafayette, 47904 IN, USA
Email: mivantys@purdue.edu

ABSTRACT

This paper presents a comparison of the energetic consumption of a valveless and a valve controlled active oscillation damping system for off-road machinery. Today only passive oscillation damping systems are subject to off-road machine series production. These systems offer the advantage of no additional primary energy use for damping. However, the disadvantages are the high costs and no adaptation possibility to the operating parameters. The recent developments where valve controlled linear actuators have been used for active damping had to face several problems with too low dynamics of today's implemented control valves and the high additional energy need. These disadvantages can be avoided by using valveless linear actuators for working functions and for active damping. In fact, throttling losses are omitted and, energy recovery is possible. It will be shown based on measurement and simulation results that a suitable damping quality can be achieved with valveless linear actuators. Therefore, some aspects of the controller design will be given. Hereby, a simple acceleration sensor and standard control hardware are used. The main part will describe the energetic modelling, whereby especially precise pump loss models have been developed. The energy consumption of both systems performing active damping is compared in detail.

KEYWORDS

Displacement control, Valveless, Valve control, Active Oscillation Damping, Energy Saving, Linear Actuators

NOMENCLATURE

A_K	cylinder area [m ²]
C_H	hydraulic capacity [m ⁵ /N]
c_{uc}	spring constant, undercarriage [N/m]
d_{uc}	damping constant, undercarriage [Ns/m]
m_B	boom mass [kg]
m_L	load mass [kg]
m_{Ch}	chassis mass [kg]
M_S	pump torque losses [Nm]
n	pump speed [rpm]
Q	volume flow [m ³ /s]

V_i	displacement volume [cm ³ /s]
y	cabin vertical position [m]
ϕ	boom angular position [°]

1 - INTRODUCTION

In today's off-road machines – especially mobile machines capable of driving at fairly high speeds of up to 40 km/h like wheel loaders – oscillating accelerations at the cabin and at the boom structure represent an important factor limiting the machines productivity and the operator comfort. The accelerations have their source in forces introduced into the machine structure from the ground

through the low damped wheels and undercarriage (Fig. 1). The accelerations lead to two major problems: a comfort problem for the driver in the cabin and a safety problem for the load transported by the machine (Fig. 2). Both problems lead to a reduction of the drive speed of the machine in case the acceleration grows beyond certain limits.

Currently, three hydraulic system concepts focussed on the reduction of the oscillating acceleration in mobile working machines exist. The most basic and widely implemented concept is a passive solution where the high pressure side of the hydraulic working actuators is connected by simple switch valves with high pressure hydro-pneumatic accumulators and shut off from the rest of the hydraulic circuit (e.g. Drake and Jaecks, 1991; Hosseini, 1992; Ufheil and Rector, 1996; etc.). This concept has the advantage of no additional primary energy necessary for the additional damping in the system. The disadvantages are the very limited frequency range in which the concept produces additional damping and the cost both for implementation and maintenance of the high pressure accumulators.

Using the main electrohydraulic valve block of the standard hydraulic system, or additional faster valves if more bandwidth is necessary (which is often the case), active oscillation damping can be implemented in mobile machinery (Latour and Biener, 2002; Patel et al, 1999; etc.). In this application the controller uses additional sensors for acceleration, pressure, force or a combination to produce an additional command input for the control valve. The oscillation reduction using valve control comes at the price of high additional primary energy. Valve controlled actuators – usually in combination with load sensing controlled pumps – are even for standard position control not an energy-efficient concept. For active oscillation damping the valve is commanded from negative to positive position in short time intervals. As soon as the valve is opened energy is lost at the valve itself. Using valve control, no energy can be recovered, e.g. while lowering a load, this becomes of higher importance for active damping as all additional energy for this task is lost and cannot even partly be reused. All energy lost is transformed into heat energy. This energy has to be transferred out of the system by additional cooling effort.

Using a hydraulic system concept with a displacement controlled (also pump controlled or valveless) actuator in closed hydraulic circuit, energy recovery is possible. The concept uses the hydraulic pump itself as final control element and has proven itself in earlier studies useful for the high bandwidth demanding task of active oscillation damping (Rahmfeld, Ivantysynova and Eggers, 2004). This concept has been analysed concerning its energetic behaviour and compared to a standard hydraulic system with valve controlled actuator and load sensing controlled pump. The results of the analysis and

the comparison will be presented in the main part of this document.

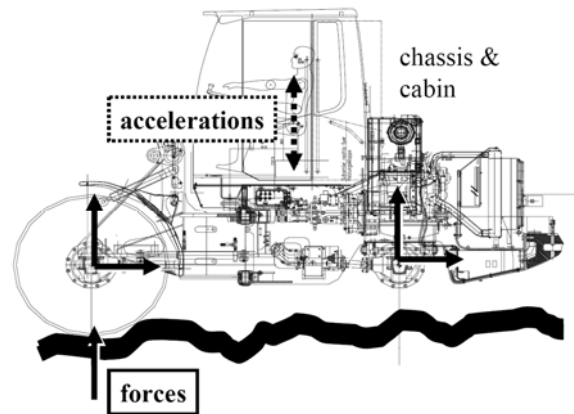

Fig. 1: Sources for accelerations at the cabin of an off-road working machine

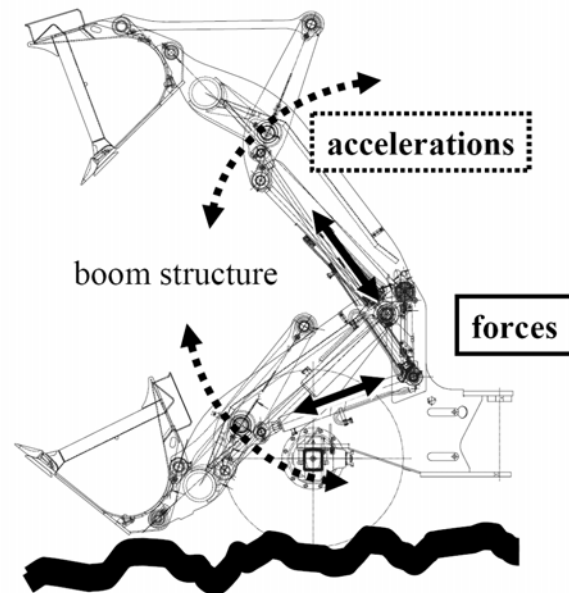

Fig. 2: Accelerations at the boom structure of a mobile working machine

2 - VALVELESS ACTIVE OSCILLATION DAMPING FOR OFFROAD VEHICLES

Rahmfeld (2002) developed a hydraulic circuit solution using single rod cylinders in closed circuit with an additional low pressure level to compensate for the different volume flows in and out of the two cylinder chambers (see also Rahmfeld, Ivantysynova and Weber, 2004). Using the variable displacement pump as final control element, this system has three major advantages over today's standard valve controlled systems:

1. higher energy efficiency by omission of throttling losses and the possibility of energy recovery,
2. simplification of the system itself by use of less components,
3. higher dynamic with easier control possible.

Fig. 3 displays the linear valveless actuator concept. The single rod cylinders (2) are controlled by the electrohydraulic variable displacement pump (1). The pilot operated check valves (3_1 , 3_2) allow volume flow from the low pressure line (LP) into the main hydraulic lines and back to compensate for the different volume flow in and out of the actuator chambers.

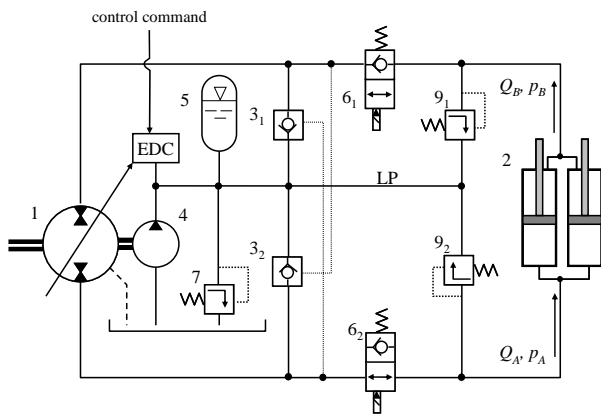

Fig. 3: Hydraulic circuit solution: Displacement controlled linear actuator

The low pressure level is equipped with a charge pump with fixed displacement volume (4) and a hydro-pneumatic low-pressure accumulator (5). Maximum low pressure is adjusted by a relief valve (7). The main hydraulic lines can be locked by two shut-off valves (6_1 and 6_2) and are connected to the low pressure line by two pressure relief valves (9_1 and 9_2). All required components could be integrated in the pump housing.

In a machine with more than one displacement controlled actuator like for the wheel loader, the low pressure lines can be coupled (Fig. 4) and the number of hydraulic system components can be reduced once more. Additionally, energy recovered by one displacement pump running in motoring mode can be reused by the other actuator or the hydrostatic transmission drive (19). In this case the energy is transferred through the distributing gear (17).

The application of valveless active oscillation damping has been implemented in a technology demonstrator wheel loader (pre-series) machine by Rahmfeld, Ivantynova and Eggers (2004). In this work a wheel loader with displacement controlled linear actuators has been equipped with two capacitive acceleration sensors at the boom structure and at the cabin. This type of sensor

proved to be cost efficient and as well as comparable to pressure sensors. The boom sensor signal could be used as input for additional acceleration controller implemented in the electric CAN-bus controller of the machine to act directly on the displacement control unit of the variable displacement axial piston pump of the lifting actuators. The potential of this concept could be demonstrated in experimental drive tests.

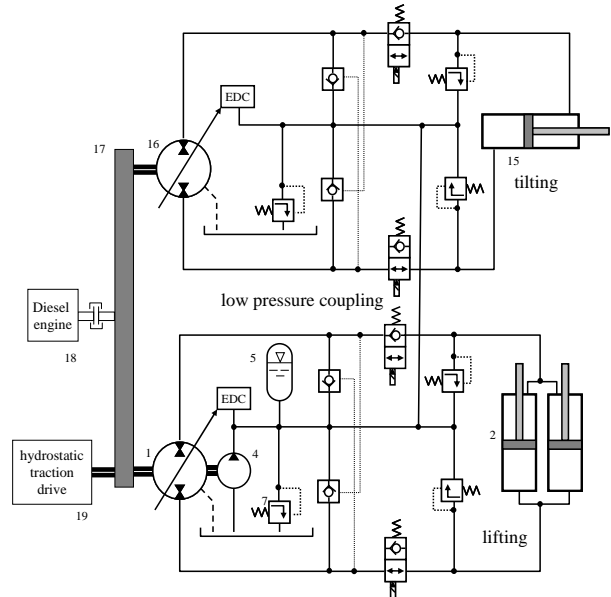

Fig. 4: Wheel loader with valveless working functions and coupled low pressure level

Within these earlier investigations measurement results of the electrohydraulic pump were analysed to reveal a strong amplitude dependency of the pump dynamics, as it is typical for nonlinear systems. Using these measurements a linear pump model could be created as a PT2 transfer element with a damping of $D_{\text{pump}} = 0.456$ and the eigenfrequencies for different commanded displacement volume amplitudes as

amplitude 30%:	$\omega_{\text{pump}} = 5.4 \text{ Hz} = 34 \text{ rad/s}$
amplitude 12.5 %:	$\omega_{\text{pump}} = 7.8 \text{ Hz} = 49 \text{ rad/s}$
amplitude 5 %:	$\omega_{\text{pump}} = 9.4 \text{ Hz} = 59 \text{ rad/s}$

Clearly the amplitude dependency of the pump dynamics becomes visible. Although this information may be sufficient to create a linear model of the hydraulic system and to proceed with a systematic controller design, these findings show the demand for a nonlinear model of the pump and its control system with similar behaviour for simulation purposes.

3 - CONTROL CONCEPT

Fig. 5 displays the linear block diagram of the control plant consisting of the electrohydraulic pump and the single rod cylinders. In case of manual control by the driver this system is controlled in open loop (OL) providing good control quality for the driver. As soon as no input is produced through the joystick, the system switches to closed loop (CL) maintaining the angular position of the boom ϕ with the help of the position controller. This controller is enhanced with two nonlinear compensations for pump speed and kinematic to provide nearly maximum controller gain at all operating points. To facilitate acceleration control for the boom and the cabin of the machine, two additional control loops are implemented. The input for the control loops is provided by the acceleration sensors at the boom and the cabin.

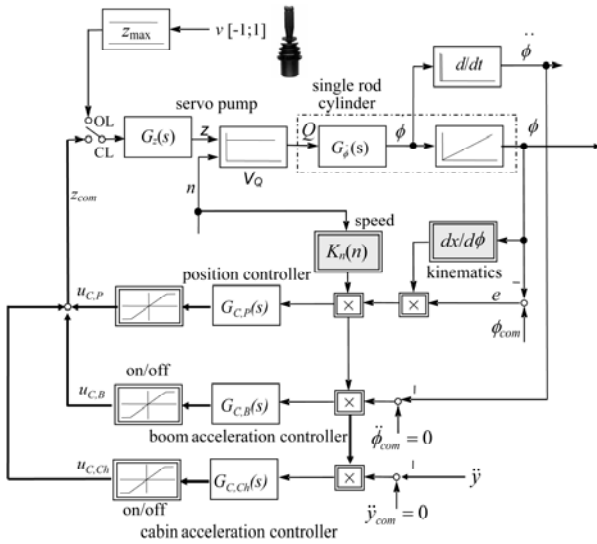

Fig. 5: Position and acceleration control loops

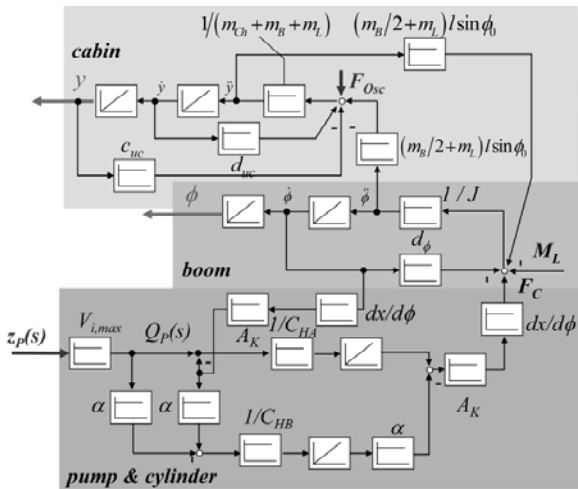

Fig. 6: Linearized block diagram of pump, cylinder, boom and cabin

To be able to design the acceleration controller systematically, linear models of the control plant and the mechanical model of the boom and the cabin have been created (Fig. 6). The model with two degrees of freedom – angular boom position ϕ and vertical chassis position y – is based on two differential equations: the equation of rotational motion around the connecting point between chassis and boom:

$$J \ddot{\phi} = -d_{\phi} \dot{\phi} + (m_L + m_B/2) l \sin \phi (g - \ddot{y}) + (A_K (p_A - \alpha p_B) - F_R(\dot{x}) - m \ddot{x}) \frac{dx}{d\phi} \quad (1)$$

and the equation of linear motion of the chassis

$$(m_{Ch} + m_B + m_L) \ddot{y} + d_{uc} \dot{y} + c_{us} y = (m_B/2 + m_L) l \ddot{\phi} + F_{Osc} \quad (2)$$

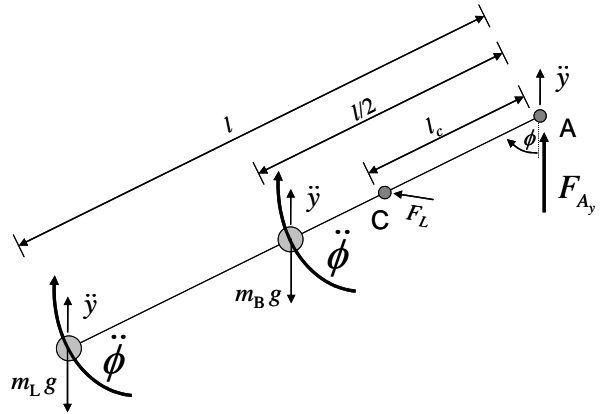

Fig. 7: Boom dynamic model

These equations can be derived by cutting the boom structure (Fig. 7) and the chassis model (Fig. 8) free. The cylinder force is calculated in this approach as:

$$F_L = A_K (p_A - \alpha p_B) - F_R(\dot{x}) - m \ddot{x} \quad (3)$$

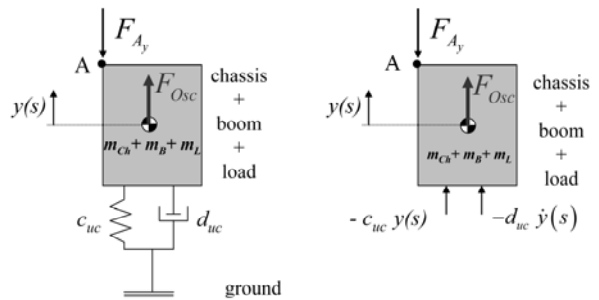

Fig. 8: Chassis dynamic model

Using this linearized model, controller up to the 1st order have been designed both for cabin and acceleration control. In nonlinear simulations good damping quality could be achieved using PDT1 controller, significant cabin acceleration reduction could not be produced due to the simplified cabin model. Selecting the pole of the boom acceleration controller near the cabin poles at approximately 1 rad/s and the zero at the frequency of the dominating pole pair of the differential cylinders at 53 rad/s made amplitude reductions of the acceleration of 35% possible using a model of the standard pump control system. The *Bode* diagram of the closed acceleration control loop can be seen in Fig. 9.

The energetic evaluation and comparison in this document focuses on equivalent acceleration amplitude reduction at the boom using the two different system solutions: valveless and load-sensing.

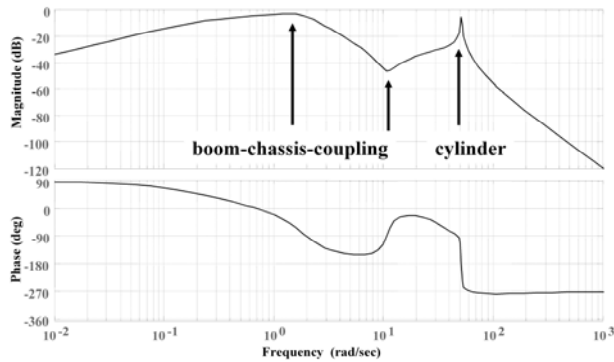

Fig. 9: Closed loop bode diagram, 1st order boom acceleration control

4 - ENERGETIC MODEL

To be able to calculate the necessary primary energy for a displacement controlled active oscillation (acceleration) damping approach the precise modelling of the energy losses of the hydraulic pump (and of the other hydraulic components) is crucial. Using displacement control, the pump can change between pumping and motoring mode. Loss models for the single quadrants of such a pump show significantly different behaviour especially around small displacement volumes. For the task of acceleration control the hydraulic pump is commanded from positive to negative displacement and vice versa in short time intervals. To ensure a smoothly running simulation model for these changes in displacement it is important to use a loss model with continuous behaviour at the operating points with little displacement volume and/or pressure difference.

Figure 10 displays the four single quadrant models of the torque losses of an axial piston swash plate type pump with a maximum displacement volume of 75 cm³/rev generated with the program *POLYMOD* based

on measurements (markers). *POLYMOD* represents a mathematical interpolation of the measurements by a polynomial as a function of pump speed, pressure difference and displacement for one oil temperature. The torque losses (Eq. 4) and the volumetric losses (Eq. 5) of the pump are defined through the coefficients of the polynomials K_M and K_Q . These coefficients are derived by selecting a surface fitting best to the measurement data using the method of least squares. The discontinuity becomes obvious in this figure. When the measurement data of all four quadrants is used for interpolation using *POLYMOD* a continuous model can be created (Fig. 11).

The *Sankey* (energy flow) diagram in Fig. 12 describes the main loss components of the displacement controlled actuator. For this application the electrohydraulic pump is the main loss source.

Furthermore the *Sankey* diagram demonstrates that the energy recovered in the displacement controlled system and reused in other actuators reduces the total amount of consumed primary energy by the machine and makes it more efficient. For this effect, it is assumed that the recovered energy at the pump shaft (the pump losses are also recovered) is used by other drives in the machine system like transmission, steering, braking, etc.

$$M_S(V_i, n, \Delta p)_{T=\text{konstant}} = \sum_{i_1=0}^{I_1} \sum_{i_2=0}^{I_2} \sum_{i_3=0}^{I_3} K_M(i_1, i_2, i_3) \cdot V_i^{i_1} \cdot n^{i_2} \cdot \Delta p^{i_3} \quad (4)$$

$$Q_S(V_i, n, \Delta p)_{T=\text{konstant}} = \sum_{i_1=0}^{I_1} \sum_{i_2=0}^{I_2} \sum_{i_3=0}^{I_3} K_Q(i_1, i_2, i_3) \cdot V_i^{i_1} \cdot n^{i_2} \cdot \Delta p^{i_3} \quad (5)$$

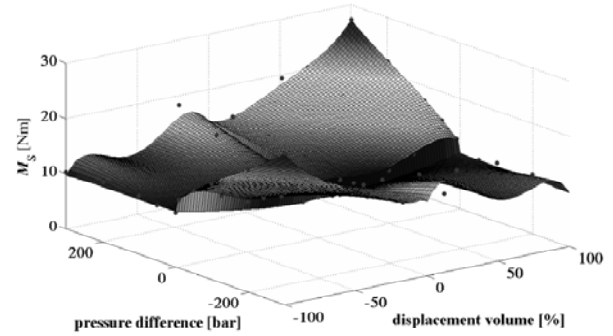

Fig. 10: Four combined single quadrant torque loss models

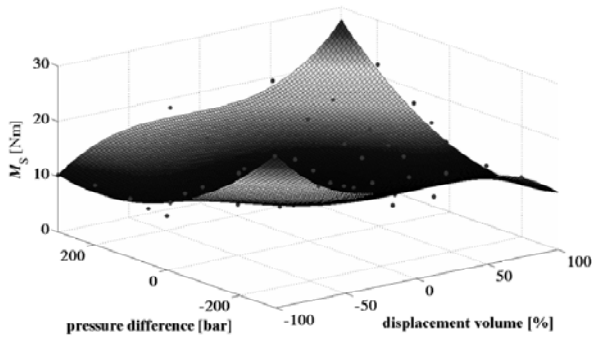

Fig. 11: Four quadrant torque loss model

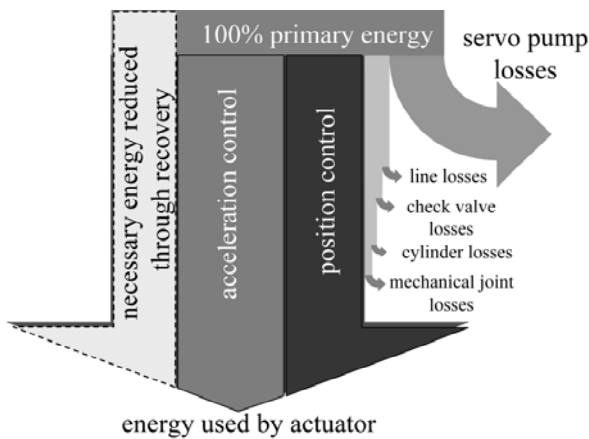

Fig. 12: Sankey diagram, displacement control

The loss behaviour of the hydraulic valves has been calculated based on the volume flow - pressure drop - diagrams issued by the manufacturers.

5 - VALVE CONTROLLED ACTIVE DAMPING

A standard open circuit hydraulic concept for active damping using valve control as primary and a load sensing controlled pump as secondary control element has been used in earlier applications for active oscillation damping (Latour and Biener, 2002; Berger and Patel, 1999; etc.). Fig. 13 compares the basic concept of valve and displacement control using simplified circuit diagrams.

To compare the primary energy necessary to provide equivalent damping quality using displacement control as well as valve control, additional to the nonlinear model of the displacement controlled machine, the model of a virtual valve controlled hydraulic system with a load sensing controlled pump as secondary control element has been developed. The dynamics of the load sensing valve have been tuned to produce equivalent damping quality as achieved with the displacement controlled system. To provide a useful primary position control, the

load sensing valve itself has been designed with zero overlap in contrast to a standard load sensing valve with positive overlap. I.e., the load sensing valve is during position control always actuated. The pure position control alone could be done more efficiently by a standard load sensing system, however, for active damping the valve is always in actuation.

The Sankey diagram of the valve controlled actuator in Fig. 14 demonstrates two important facts compared to a displacement controlled system: the system has two major loss sources – the pump and the main valve – and the consumed primary energy cannot be reduced with the help of energy recovery.

6 - SIMULATION MODEL BASED ON MEASUREMENTS

In earlier measurements (Rahmfeld, Ivantysynova and Eggers, 2004) only the quality of displacement controlled active damping was looked upon. Drive test were conducted with the focus on the amplitude reduction of oscillations at the boom structure of a wheel loader. The measurements left two questions unanswered: how much energy is necessary to provide the achieved damping quality and how much energy would be necessary by using a valve controlled load sensing system? To answer these questions a non-linear model of the hydraulic circuits and its components and a multi-body model of the boom structure and the cabin were used in combination with measurement based loss models for the hydraulic pump and other used components.

The pump and the remaining components of the hydraulic circuit for this simulation system as well as the position and acceleration controller have been generated as non-linear models in Matlab/Simulink 7.0. The multi-body models of the boom structure and the cabin have been created in Matlab/SimMechanics 2.0 providing the tools for a non-linear simulation within one program, avoiding a complex co-simulation, see Fig. 15.

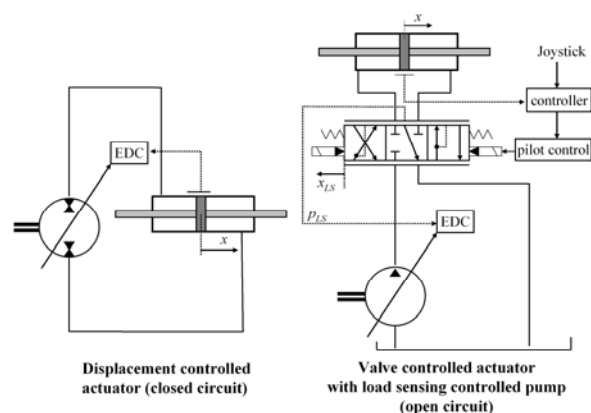

Fig. 13: Comparison: Displacement control – Load sensing valve control

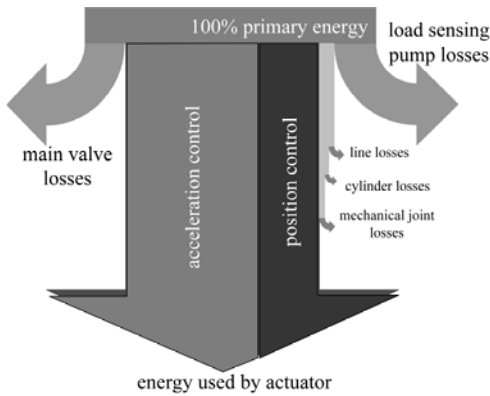

Fig. 14: Sankey diagram, valve control

The hydraulic circuit has been modelled with closed circuit displacement controlled on the one hand and for comparison as open circuit load sensing valve controlled. In both cases the same pump loss model has been used. In case of the valve controlled actuator the pump has been equipped with an electro-hydraulic pressure control system and a zero-overlap valve with enough bandwidth to produce a damping quality similar to the displacement controlled system. As multi-body model a model of the boom structure with one rotational degree of freedom was extended with a basic model of the chassis as a mass-spring-damper combination with one translation degree of freedom in vertical direction. This model offers the possibility to reproduce the accelerations at the cabin directly from the measured drive test results by introducing a force F_{Osc} (Fig. 6, 15) in vertical direction of the chassis. The force is generated using the inverted transfer function (Eq. 6) of the chassis dynamics and the acceleration measured at the chassis in the drive tests.

$$G_{osc}(s) = \frac{F_{osc}(s)}{\ddot{y}_{meas}(s)} = \frac{(m_L + m_B + m_{Ch})s^2 + d_{uc}s + c_{uc}}{s^2} \quad (6)$$

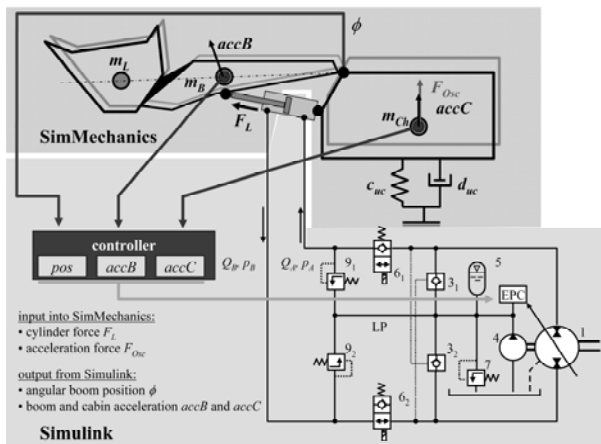

Fig. 15: Hydro-mechanical simulation using Matlab Simulink and SimMechanics

7 - COMPARISON FOR WHEEL LOADER DRIVING MANOUVRE

As basis for the comparison of the two hydraulic concepts concerning their energetic behaviour when used for active oscillation damping, the measurements of a drive test with deactivated control was selected. With these results the natural accelerations at the boom and at the cabin could be recreated to be counteracted by the designed acceleration controllers. Within the selected drive test the machine was driven over three groups of high obstacles (Fig. 16). The drive speed was approximately 10 km/h. Out of the drive test measurements a 12 s long phase was selected to be used as input for the non-linear simulation models. The utilized wheel loader has a maximum engine power of 82 kW.

Using the acceleration input and a selected first order acceleration controller the effective pump torque has been calculated for both system concepts. The calculations have been carried out for three different load scenarios: unloaded, loaded with 1 ton in the bucket and loaded with 2.5 ton. Figure 17 shows the effective pump torque of the pump for the LS valve controlled and the valveless system for the two most extreme load cases. It can be easily observed that the pump torque in the displacement controlled system drops below the minimum pump moment – indicated by the black horizontal line – as described in chapter 4. This means the pump is running in motoring mode, compensating for its own losses.

For an actuator moving not only the boom mass but an additional 2.5 ton of load, the pump is not only running in motoring mode in a high number of time frames but the pressure difference is high enough that the pump when running in motoring mode can drive other units running on the same shaft, i.e. the recovered energy is transferred mechanically to other units as steering pump, hydrostatic drive or others. Since the active oscillation damping will be used mainly while the machine is moving, it is very probable that the energy can be fully recovered. In fact the energy can be transferred to e.g. the transmission drive which will thereby take less torque from the combustion engine so that the engine can reduce the fuel injection. The engine itself will therefore have to produce less primary energy for the system and consume less fuel.

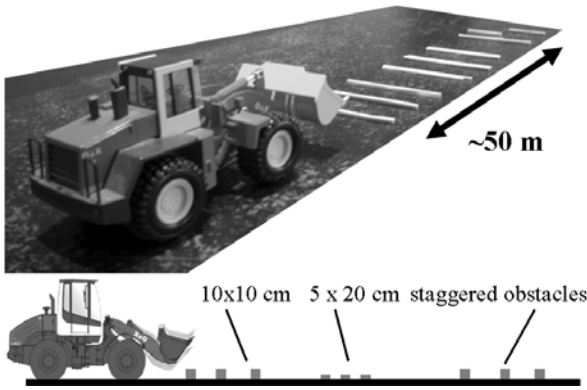

Fig. 16: Obstacle proving ground for drive tests

The effective pump shaft energy can be calculated using equation 7. The effective pump shaft torque defined

by the theoretical torque M_{th} and the torque losses M_S as presented in chapter 4 and stated in equation 8.

$$P_{mech} = 2\pi M_e n_{pump} \quad (7)$$

$$M_e = M_{th} + M_S \quad (8)$$

The mechanical work of the pump, running at constant speed n_{pump} , is calculated by integrating the pump shaft energy over the simulation time (Eq. 9).

$$W_{mech} = \int_0^T P_{mech}(t) dt = 2\pi n_{pump} \int_0^T M_e(t) dt \quad (9)$$

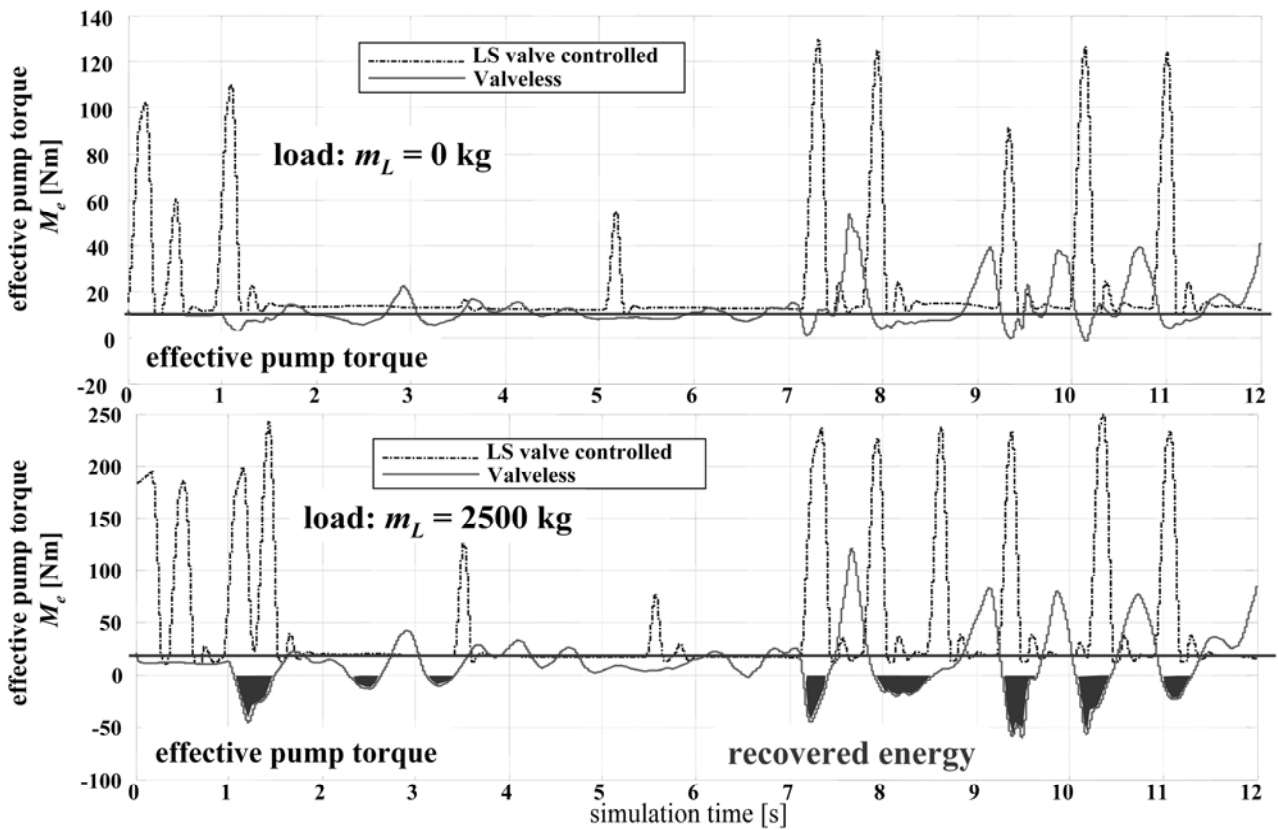

Fig. 47: Effective pump torque, two load cases (0 ton and 2.5 ton)

Figure 18 demonstrates the amount of primary energy consumed by the two compared system solutions for similar oscillation damping quality both for the position control of the boom structure (black) and parallel acting acceleration control (grey). The additional energy used for active damping is displayed in this graphic as percent of the energy amount used for position control. The amount of

energy saved through recovery in the displacement controlled system is marked in white. In this comparison the energetic advantage of the displacement controlled system – especially for high load – becomes obvious: a lower additional percentage of primary energy is necessary for the damping and a high amount of energy can be reused.

The simulation results for the three load cases reveal the energy amount for the simulation cycle as:

Load Sensing valve controlled

unloaded:	position control:	37.5 kJ
	acceleration control:	12.3 kJ (+ 33%)
2.5 ton load:	position control:	65.8 kJ
	acceleration control:	35.9 kJ (+ 55%)

Displacement controlled (valveless)

unloaded:	position control:	22.0 kJ
	acceleration control:	6.8 kJ (+ 31%)
	recovered energy:	0.0 kJ (0%)
2.5 ton load:	position control:	26.7 kJ
	acceleration control:	13.5 kJ (+51%)
	recovered energy:	-12.4 kJ (92%)

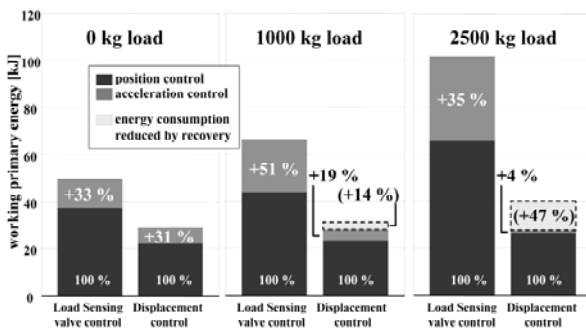

Fig. 18: Consumption of primary energy for position and acceleration control, valve control vs. displacement control

8 - SUMMARY AND CONCLUSION

To analyze the energetic behaviour of the two different drive concepts – load sensing valve control and displacement control – the loss behaviour of the hydraulic components of each system has been modelled and a four quadrant loss model for the hydraulic pump has been created. The models have been used in combination with extensive non-linear models of the dynamic behaviour of the hydraulic and the mechanic system to simulate two different system concept providing comparable damping quality. The simulations based on measurement results were used for an analysis of the energetic behaviour. A comparison could be carried out revealing strong advantages of the displacement controlled actuator especially for high load masses. The ability of a displacement controlled system to recover energy allows the system to reuse a large amount of the energy used to actively damp the boom structure by running the pump in motoring mode. For the first time this has been simulated to this extend.

In a valve controlled system providing similar damping quality not only is more energy consumed during the damping, all energy lost at the valve is converted into heat energy. This energy has to be transferred out of the system

with additional cooling and thereby additional energy consumption. This investigation proves why valve controlled active damping has not been implemented in series production off-road machines.

REFERENCES

- Berger, A. D. and Patel, K. B.** 1999. Active Ride Control System for Off-road Vehicles. *US Patent No. 5.897.287.*
- Drake, F. J. and Jaecks, B. K.** 1991. Hydraulic System for a Wheel Loader. *US Patent No. 5.195.864.*
- Frediani, S., Gianoglio, R. and Weber, J.** 2003. Electro Hydraulic Active Ride Control. *4. IFK (4th Int. Fluid Power Conference)*, pp. 129-138, Dresden, Germany.
- Hosseini, J.** 1992. Automatic Ride Control. *US Patent No. 5.147172.*
- Latour, Ch. and Biener, R.** 2002. Comparison of active and passive oscillation suppression systems for wheel loaders. *3. IFK (3rd Int. Fluid Power Conference)*, T4 Vol. 2, pp. 101-112, Aachen.
- Patel, K. B., Lin, H. C., Berger, A. D., Farag, W. and Khan, A. A.** 1999. EDC Draft Force Based Ride Controller. *US Patent No. 6.196.327.*
- Rahmfeld, R.** 2002. *Development and Control of Energy Saving Hydraulic Servo Drives for Mobile Systems.* Doctoral thesis TU Hamburg-Harburg (Germany), Vol. 12, No. 527, VDI-Verlag, Düsseldorf, Germany.
- Rahmfeld, R. and Ivantysynova, M.** 2003. New Displacement Controlled Linear Actuator Technology – a Suitable Control Element for Active Oscillation Damping. *The 8th Scandinavian Inter-national Conference on Fluid Power (SICFP'03)*, pp. 1139-1154, Tampere, Finland.
- Rahmfeld, R., Ivantysynova, M. and Eggers, B.** 2004. Active Vibration Damping for Off-Road Vehicles using Valveless Linear Actuators. *SAE Commercial Vehicle Engineering Congress and Exhibition, Chicago, USA.*
- Rahmfeld, R., Ivantysynova, M. and Weber, J.** 2004. Displacement Controlled Wheel Loader – a simple and clever Solution. *4th IFK (Int. Fluid Power Conference)*, pp. 183-196, Dresden, Germany.
- Ufheil, S. and Rector, S. W.** 1996. Programmable Ride Control. *US Patent No. 5.520.499.*