

# MOTION CONTROL OF ELECTROMAGNETIC RECIPROCATING ACTUATOR FOR METAL BELLOWS PUMP

Yasukazu SATO\* and Yasuhiro MATSUSHITA\*

\* Department of Mechanical Engineering, Faculty of Engineering  
Yokohama National University  
79-5 Tokowadai, Hodogayaku, Yokohama, Kanagawa, 240-8501 Japan  
(E-mail: yasukazu@ynu.ac.jp)

## ABSTRACT

A resin-made-bellows pump is used practically as a chemical pump application. Its discharge pressure is low as 0.1MPa in general; therefore, its applicable fields are limited. In order to make the pressure higher, we developed a metal bellows pump driven by an electromagnetic reciprocating actuator for various industrial applications with the pressure of over 10MPa and non-leakage performance. As the pressure becomes higher, larger output force is required to the actuator. The developed electromagnetic actuator can drive the bellows by reciprocating motion in the stroke of 1mm with the maximum output force of 1400N. However, the high-speed motion of the actuator by the armature position- and velocity-sensorless control makes issue that the armature collides hard with the stator and generates the noise and vibration. In this paper, the motion control method to reduce the mechanical collision in the actuator without position- and velocity-sensors is presented.

## KEY WORDS

Bellows Pump, Electromagnetic Actuator, Noise Reduction, Power Saving, Non-leakage Pump

## NOMENCLATURE

$E$  : Voltage supplied from electric power source  
 $f$  : Driving (reciprocating) frequency  
 $F_{mag}$  : Electromagnetic attractive force  
of the actuator  
 $g$  : airgap between armature and stator  
 $i$  : Current flowing through coil  
 $L$  : Inductance of coil  
 $P$  : Discharge pressure of the pump  
 $Q$  : Flow rate  
 $R$  : Resistance of coil  
 $S$  : Sound pressure level

$x$  : Displacement of armature.  
 $\eta$  : Volumetric efficiency  
 $\lambda$  : Magnetic flux linkage

## INTRODUCTION

A bellows pump has advantages in application to apparatuses which allow no leakage because of its non-leakage structure. Due to the limitation of mechanical strength of bellows material, the applicable fields of a bellow pump are generally limited in low pressure application such as semiconductor manufacturing, medical and chemical processes using

pressure range of 0.1 ~ 1MPa. By improvement of discharge pressure up to 10 MPa and over, the applicable fields of bellows pump would be expanded to various applications such as a direct fuel injection pump for automobile and a pump for very low viscosity fluid, and so on. In recent years, the metal bellows having enough mechanical strength for high pressure inside the bellows was developed. Photo 1 shows an example of metal bellows. It has flexibility in axial direction and moreover restricts expansion in radial direction against high inner pressure. Owing to the development of metal bellows for high inner pressure, the improvement of bellows pump for higher application is progressing. In this paper, a metal bellows pump driven by an electromagnetic reciprocating actuator for various industrial applications with the pressure of 10MPa and non-leakage performance is developed. The motion control method to reduce the noise and vibration without sensors is presented. Furthermore, it is indicated that this method is also effective to power-saving drive.

**DRIVE MODE OF BELLOWS PUMP**

Electromagnetic drive mode to expand /contract the bellows is generally categorized to either of two methods; one is the rotary type in which rotation of motor is transformed to reciprocating motion by a cam, the other is the linear type using linear or reciprocating actuator. The rotary type is suitable for large flow discharge using the multiphase cam to activate bellows several times in one rotation cycle. It also generates smooth motion of the bellows easily, using appropriate cam profile. However, it needs motion transforming elements such as a cam, cam-follower and bearings, and so on. In case of the direct flow control, the rotational speed control of the drive motor is required. On contrary, the linear type has merit of simple structure and is easy to control flow rate by the reciprocating frequency control of linear actuator. However, it is required high speed reciprocating for large flow discharge and is also



Photo 1 Metal bellows

required large actuator force compatible to high discharge pressure. As described above, both drive modes has strong points and shortcomings. In this paper, the linear type is adopted for the drive mode of bellows pump because of its simple structure and easiness of flow rate control.

**METAL BELLOWS PUMP DRIVEN BY ELECTROMAGNETIC RECIPROCATING ACTUATOR**

A prototype electromagnetic reciprocating actuator with the maximum thrust force of 1400N and the stroke of 1mm is manufactured. The maximum thrust force is compatible to the pressure of 5 MPa which is upper limit of inner pressure of the bellows used in the prototype pump.

Figure 1 and Fig. 2 show the configuration of the bellows pump and electric circuit of actuator driver, respectively. Alternate energizing of the coil “A” and “B” generates reciprocating motion of the armature “A” and “B”, which are connected by the rod through the center hole of the stator, and then the bellows units located at the both side of the actuator expand and contract. The armature is centered by the restitutive force of the bellows when non-energizing of the coil. The flow direction is controlled by the reed valves on the each bellows unit. The flow discharged from the each bellows unit join in the pump body, and then flow out to the outside. Table 1 shows the specifications of

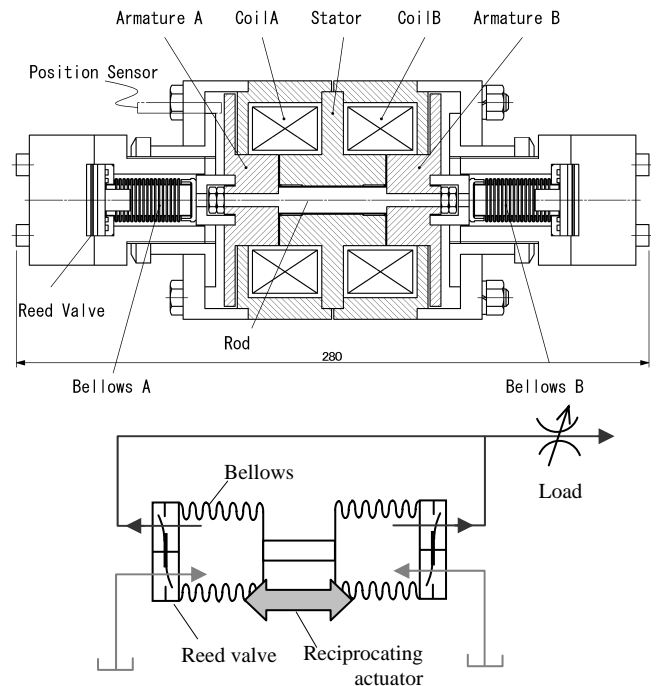

Fig.1 Metal bellows pump driven by an electromagnetic reciprocating actuator

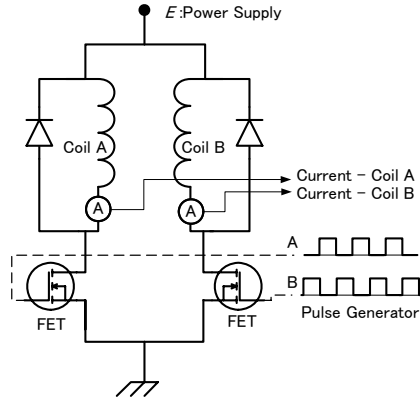

Fig.2 Conventional electric driver

the bellows used in the pump.

When the armature is located at a distance of  $x$  from the stator, the electromagnetic attractive force at the coil current  $i$  is roughly estimated by the following equation [1].

$$F_{mag} = \frac{i^2}{2} \frac{dL}{dx} \quad (1)$$

The inductance  $L$  is assumed the function of  $x$  and given by

$$L(x) = \frac{k_1}{k_2x + k_3} \approx \frac{k_1}{k_2x} \quad (2)$$

where,  $k_1$ ,  $k_2$  and  $k_3$  are constants determined by the shape of the armature and stator and the turn number of the coil. In case of very small radial clearance between the armature and stator,  $k_3$  is negligible. Consequently, the electromagnetic attractive force is expressed by

$$F_{mag} = -\frac{k_1}{2k_2} \cdot \frac{i^2}{x^2} \propto \frac{1}{x^2} \quad (3)$$

where, the minus sign indicates that the force tends to decrease the airgap. Thus, the electromagnetic attractive force is in inverse proportion to square of the airgap. As  $k_1/k_2$  is proportional to the cross-sectional area of the magnetic pole at the airgap, an auxiliary flange shown in Fig.3 contributes to strengthen the magnetic force.

Actual magnetic material has nonlinearity in its magnetization characteristics. The leakage and fringing of magnetic flux flow should be also considered. As Eq. (3) is insufficient for detail design of the electromagnetic actuator, FEM electromagnetic field analysis is applied to the design of the electromagnetic circuit of the actuator. A half of the actuator is enough to the analyzed area, as shown in Fig. 3, because of its axis-symmetry. The armature has an auxiliary flange which improves about 20 % higher in the electromagnetic attractive force, compared with the

Table 1 Specifications of bellows

Material	Stainless steel
Outer diameter	20 mm
Inner diameter	14 mm
Number of convolution	20
Normal length	43.1mm
Actuating length	42.5mm (expand) 41.5mm (contract)
Allowable inner pressure	Over 5MPa

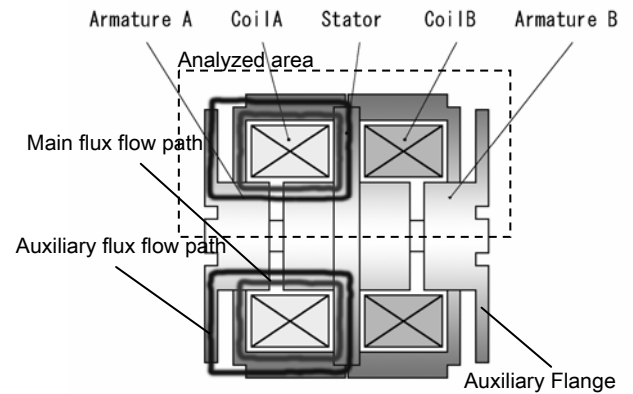

Fig. 3 Magnetic circuit of reciprocating actuator

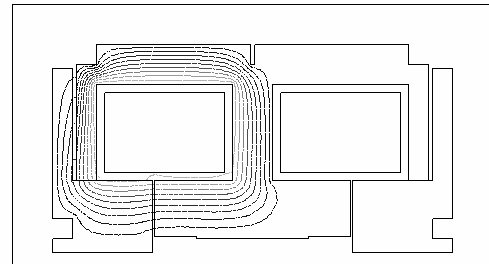

Fig. 4 Magnetic flux flow in reciprocating actuator calculated using FEM magnetic field analysis

armature having no auxiliary flange. Figure 4 depicts an analytical result of the magnetic flux flow in the actuator. It is confirmed that the magnetic flux flow passes air gaps at both the main core and the auxiliary flange effectively. The dimensions and specifications of the actuator are determined to have enough force in whole stroke against the discharge pressure of 10MPa. However, due to the limitation of the metal bellows used in the pump, the pump is driven under the pressure

of 7MPa in the performance testing described below. The coil is energized by conventional solenoid drive method shown in Fig. 2. The electric pulse with constant voltage is supplied to the coil when the FET is activated. The electromagnetic energy gradually disappears through the flywheel diode. The pump has the non-contact displacement sensor just for the measurement of the armature position in experiment, which is not used for position or velocity control. Then, the reciprocating motion of the actuator synchronizes with the alternating energizing of the coils.

### FUNDAMENTAL CHARACTERISTICS OF THE BELLOWS PUMP

Figure 5 shows the fundamental characteristics of the prototype bellows pump. The flow rate is proportional to the reciprocating frequency of the actuator, but is gradually decreased due to the decrease of the volumetric efficiency when the discharge pressure increases. This decrease arises from the bellows structure. The effort to reduce the dead volume in the bellows chamber has been achieved, but it is difficult to eliminate the dead volume completely in the folds of the bellows. Therefore, the volumetric efficiency tends to decrease in high pressure. Moreover, the bulging of each fold of the bellows under the high pressure reduces the pump performance [2].

### REDUCTION OF NOISE AND VIBRATION BY MOTION CONTROL REFERING CURRENT WAVEFORM OF COIL

The collision between the armature and stator at the stroke-end generates large noise when the actuator reciprocates fast. Because the electromagnetic attractive force under the constant current of the coil is proportional to the square of the air gap between the armature and stator, the excessive attractive force acts on the armature at the position just before collision in which the air gap is almost zero at the maximum current. Some methods are effective to reduce the collision. The armature position sensing using a displacement sensor makes it possible to speed down the armature. However, the position sensorless control is preferable from the viewpoint of robustness of the pump. The insert of a thin elastomer sheet between the armature and stator is also effective, but is accompanied with the stroke fluctuation due to the fatigue of the elastomer and the force reduction due to the increase of magnetic air gap for the thickness of the elastomer.

In this paper, a position sensorless control is proposed for the reduction of collision shock. By detection of the actuator motion at the modified electric driver, the coil current is shut off just before collision. The modified electric circuit is depicted in Fig.6. In the modified electric driver, the differentiators to detect the change of

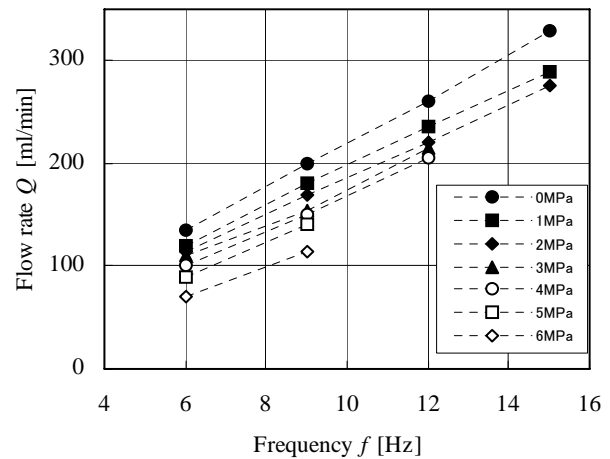

(a) Drive frequency-Flow rate characteristics

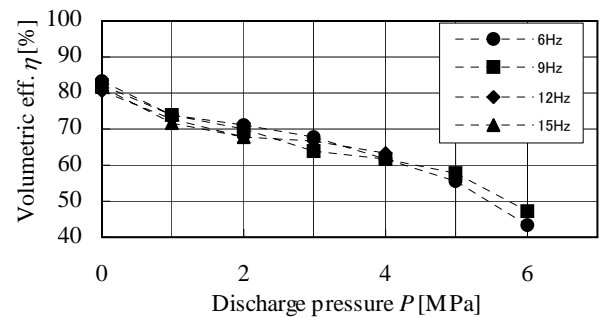

(b) Volumetric efficiency

Fig.5 Fundamental characteristics of the bellows pump

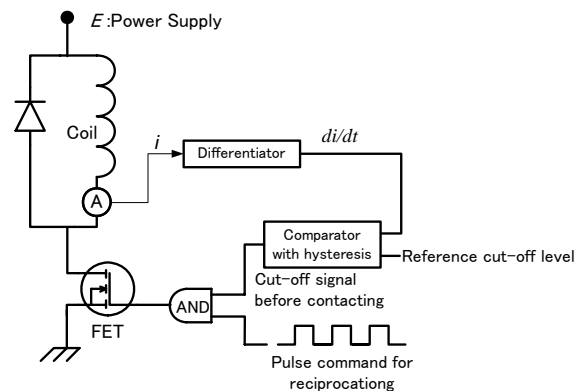

Fig.6 Additional circuit for contacting shock reduction

the coil current are inserted to the conventional circuit shown in Fig.2.

As to the magnetic circuit with the coil energized by the voltage supply  $E$ , the voltage equation of the actuator driver with moving armature is given by;

$$E(t) = iR + \frac{d\lambda}{dt} \quad (4)$$

$$= iR + L(x)\frac{di}{dt} + i\frac{dL(x)}{dx}\frac{dx}{dt}$$

where,  $\lambda$  is the flux linkage of the magnetic circuit. The term  $L(di/dt)$  is the self-inductance voltage term, and the term  $i(dL/dx)(dx/dt)$  is the speed-dependent voltage term which represents the back-EMF: electromotive force generated by the armature motion [3]. The armature displacement  $x$  is correspondent to the air gap  $g$  between the armature and stator. Assuming linear magnetic property, the inductance  $L$  varies with the armature displacement  $x$ , and given by Eq. (2).

Owing to the effect of the speed-dependent voltage term, the typical current waveform of the coil has a peak as shown in Fig.7 (a). The point "B" indicates the collision between the armature and stator. The change of slope from rising to falling around the mark "A" is detected as the resultant of high speed motion of the armature just before collision. The peak point of the current is detected as the point in which the sign of differentiation of the current. As shown in Fig.7 (b), shutting off the FET at the mark "A" reduces the shock of collision because the armature moves due to its inertia and the electromagnetic attractive force falling by the recirculation of the current through the flywheel diode. The sign of differentiation of the current is distinguished using the hysteresis comparator which has robustness against the electric noise. Figure 8 shows the flow of analog signal processing to generate the pulse signal for FET-shutting off. The shutting off timing of the FET is delayed suitably by control the hysteresis.

### TESTING OF REDUCTION OF COLLISION BETWEEN ARMATRURE AND SATATOR

For shutting off the FET just at the current peak,  $di/dt=0$ , the reciprocation of the actuator can be achieved under the pressure of 5 MPa, but falls into unstable above the pressure due to the lack of attractive force acting on the armature against the pressure. In order to make the reciprocation stable above the pressure of 5MPa, the shutting off point of the FET is shifted to the middle of downward slope before the point "B" in Fig. 7(a) from the peak,  $di/dt<0$ , by tuning of the hysteresis in the comparator. Figure 9 shows the measured coil current and the output of the differentiator.

Figure 10 shows the sound pressure level measured at a

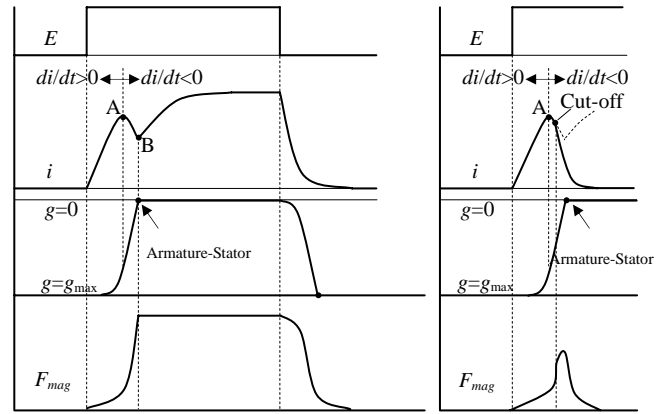

(a) Conventional drive (b) Colliding shock reduction

Fig.7 Schematic diagram of electric current waveform

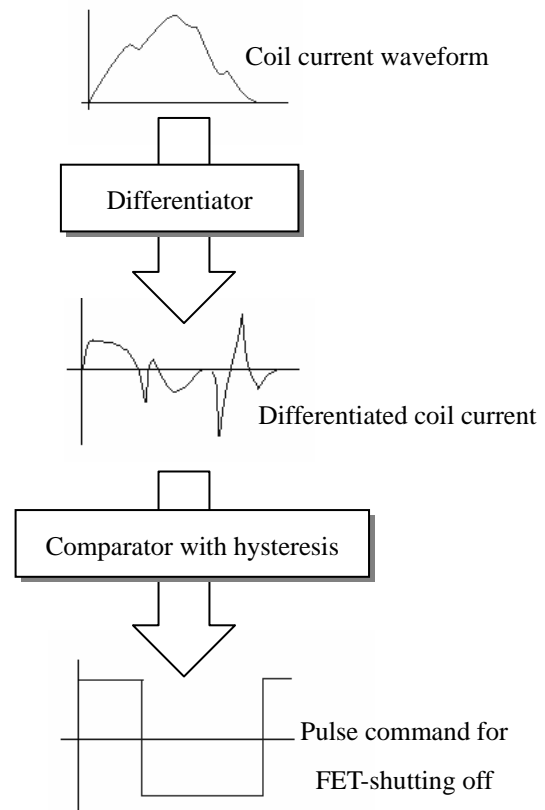

Fig.8 Conceptual diagram of analog signal processing for FET-shutting off

distance of 1m from the pump. Noise reduction during the pump working is confirmed. The noise is reduced about 4dB in whole pressure range.

## POWER-SAVING DRIVE OF ELECTROMAGNETIC RECIPROCATING BELLOWS PUMP

The noise reduction method described above also has an advantage of reduction on electric power consumption. In the conventional drive method shown in Fig.7 (a), the electric power consumption at the coil continues after the collision until the next motion is arisen. On contrary, in the noise reduction drive shown in Fig.7 (b), no electric power is consumed at the coil after the collision. Since the pumping action is completed before shutting of the current, this method does not influence the pumping action, and effective to the power saving drive, particularly low frequency reciprocation with long-term interval.

### CONCLUSIONS

The bellows pump for high pressure applications is developed using the metal bellows and the powerful electromagnetic the electromagnetic reciprocating actuator. The position-sensorless control for noise reduction at the collision between the armature and stator is proposed. It is confirmed that the noise generated by the actuator reciprocation is reduced about 4dB in whole pressure range. Furthermore, it is described that this control method is simple and effective to reduction of electric power consumption.

### ACKNOWLEDGMENT

The authors would like to thank Mr. Shinbori, NHK Spring Co.,Ltd, for supplying the bellows units which were used in this research.

### REFERENCES

1. I. Boldea, S.A. Nasar, Linear Electric Actuators and Generators, Cambridge University Press, pp. 28-32(1997)
2. Y. Sato, H. Tanaka, Electro-hydraulic Switching Valve Controlled by a GMA with Stroke Amplifier, PFLUCOME'97, pp.391-396 (1997)
3. A. E. Fitzgerald, et al, Electric Machinery 5<sup>th</sup> edition, McGraw Hill, London, pp.124-132(1992)

### APPENDIX

The prototype metal bellows pump driven by the reciprocating actuator is shown in Photo 2.

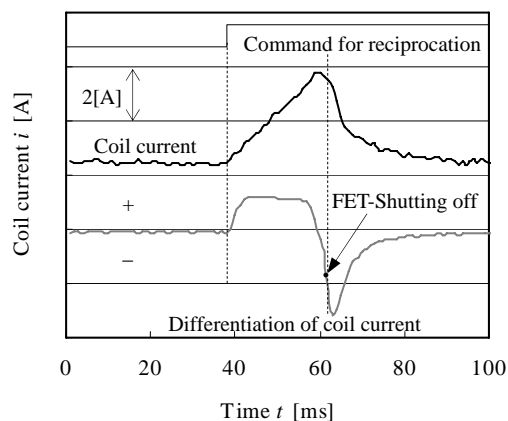

Fig.9 Measured coil current and output of differentiator

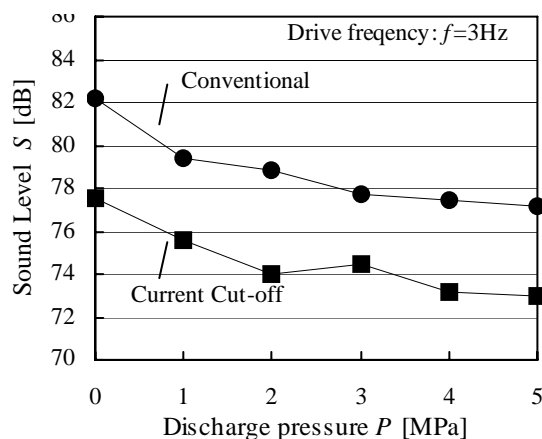

Fig.10 Comparison in sound level

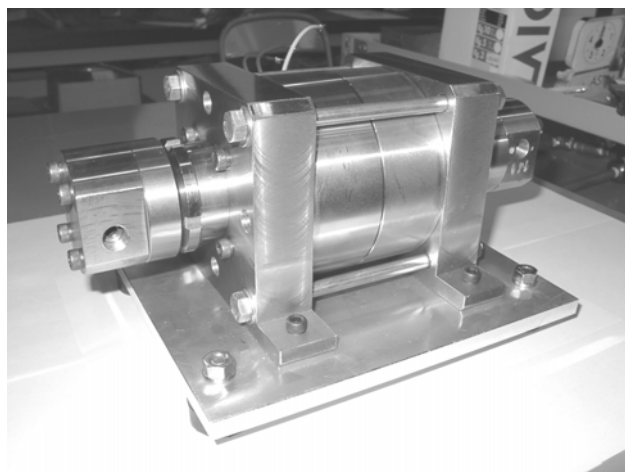

Photo 2 Prototype metal bellows pump driven by reciprocating actuator